

Spare Parts List

2006-10



MS-20 C
MS-22 C

IMPORTANT! - To assure product SAFETY and RELIABILITY, repairs, maintenance or adjustments should be performed by DOLMAR Service Centers, or other qualified service organisations. Always use DOLMAR replacement parts.

DOLMAR



A member of the *Makita* Group

995 700 252 (GB)

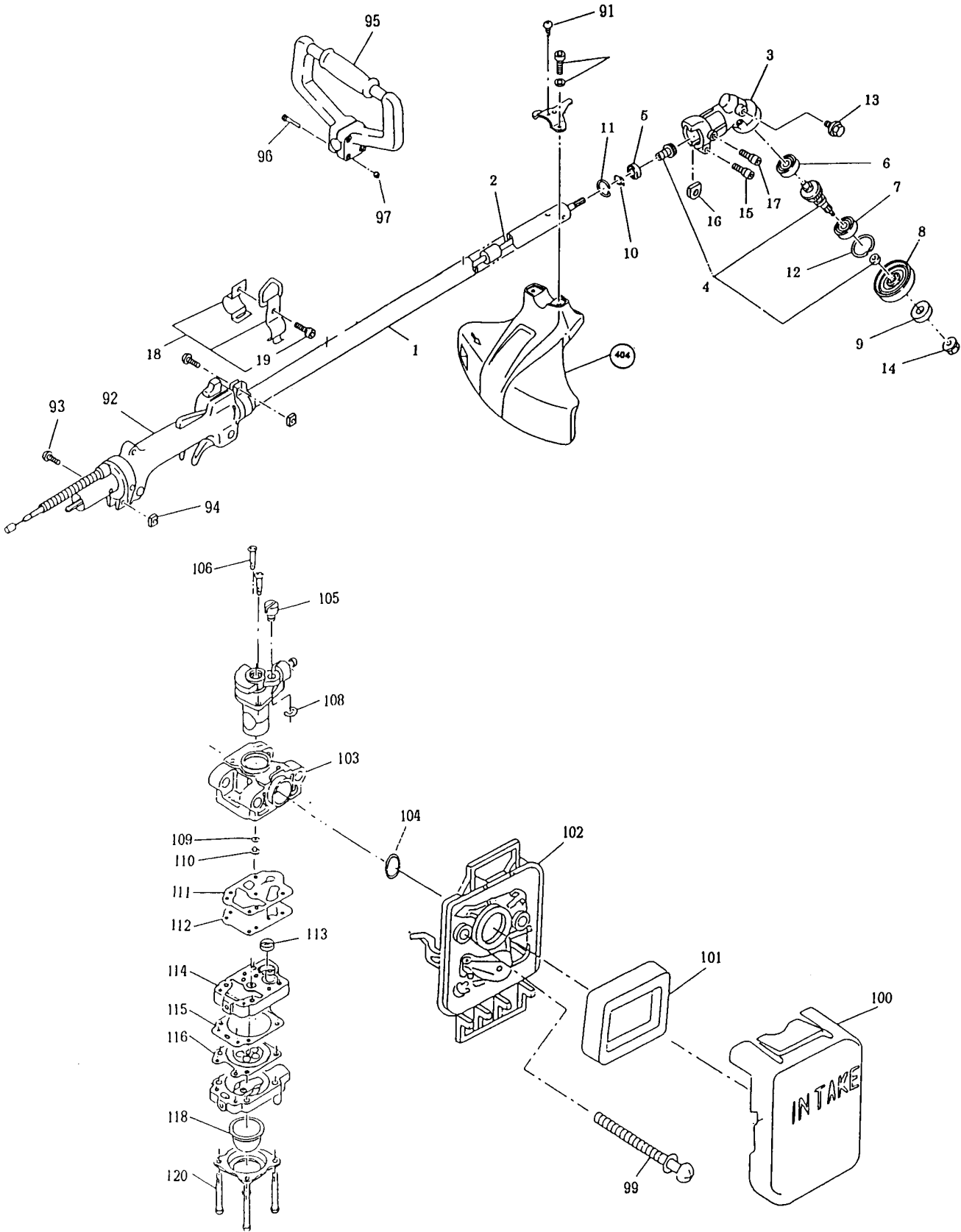

MS-20 C

DOLMAR



Page	Pos.	MS-20 C	MS-22 C	Part No.	Notes	Description	Specifications
1	1	1		374 101 000		SHAFT PIPE COMPLETE	
1	2	1		374 150 040		SHAFT	
1	3	1		374 300 400		GEAR CASE ASS'Y	INC. 4,5,6,7,8-16
1	4	1		367 300 300		CUTTER SHAFT SET	
1	5	1		381 250 030		BALL BEARING	#609ZZ
1	6	1		367 006 999		BALL BEARING	626ZZ
1	7	1		367 010 993		BALL BEARING	6000DDU
1	8	1		381 850 010		RECEIVE WASHER	
1	9	1		381 300 401		WASHER	
1	10	1		381 150 800		OUTER SNAP RING	
1	11	1		381 142 400		INNER SNAP RING	
1	12	1		381 142 600		INNER SNAP RING	
1	13	1		367 301 101		OIL BOLT	M6X9
1	14	1		381 300 402		NUT	M8
1	15	1		367 905 989		SOCKET HEAD BOLT	M5X25
1	16	1		381 150 140		GASKET	
1	17	1		367 905 990		SOCKET HEAD BOLT	M5X12
1	18	1		381 700 200		HANGER ASS'Y	INC. 19
1	19	1		374 905 985		SOCKET HEAD BOLT	M5X14
1	91	1		381 005 994		TAPPING SCREW	
1	92	1		374 500 700		CONTROL LEVER ASS'Y	INC. 93,94
1	93	2		374 906 988		SOCKET HEAD BOLT	M6X20
1	94	2		374 501 114		NUT	
1	95	1		374 450 000		HANDLE (LOOP TYPE)	
1	96	4		367 905 986		SOCKET HEAD BOLT	M5X33
1	97	4		381 270 500		NUT	M5
1	99	2		374 330 565		SCREW ASS'Y	
1	100	1		374 300 403		AIR CLEANER COVER	
1	101	1		374 300 401		AIR FILTER	
1	102	1		374 300 402		AIR CLEANER HOUSING	
1	103	1		374 600 500		CARBURETOR	INC. 105,106,108-120
1	104	1		374 606 100		O RING	
1	105	1		381 601 804		SWIVEL	
1	106	2		388 600 803		PAN HEAD SCREW	
1	108	1		381 600 512		RING	
1	109	1		381 600 101		O RING	
1	110	1		374 600 202		JET	
1	111	1		381 600 103		PUMP GASKET	
1	112	1		381 600 104		PUMP DIAPHRAGM	
1	113	1		381 600 401		INLET SCREEN	
1	114	1		374 604 613		PUMP BODY ASS'Y	INC. 113
1	115	1		381 604 604		METERING DIAPHRAGM GASKET	
1	116	2		381 600 525		METERING DIAPHRAGM ASS'Y	
1	118	1		381 600 115		PRIMER PUMP	
1	120	4		381 604 601		PUMP COVER SCREW	
1	404	1		381 800 800		PROTECTOR ASS'Y	INC. PROTECTOR CLAMP & BOLT

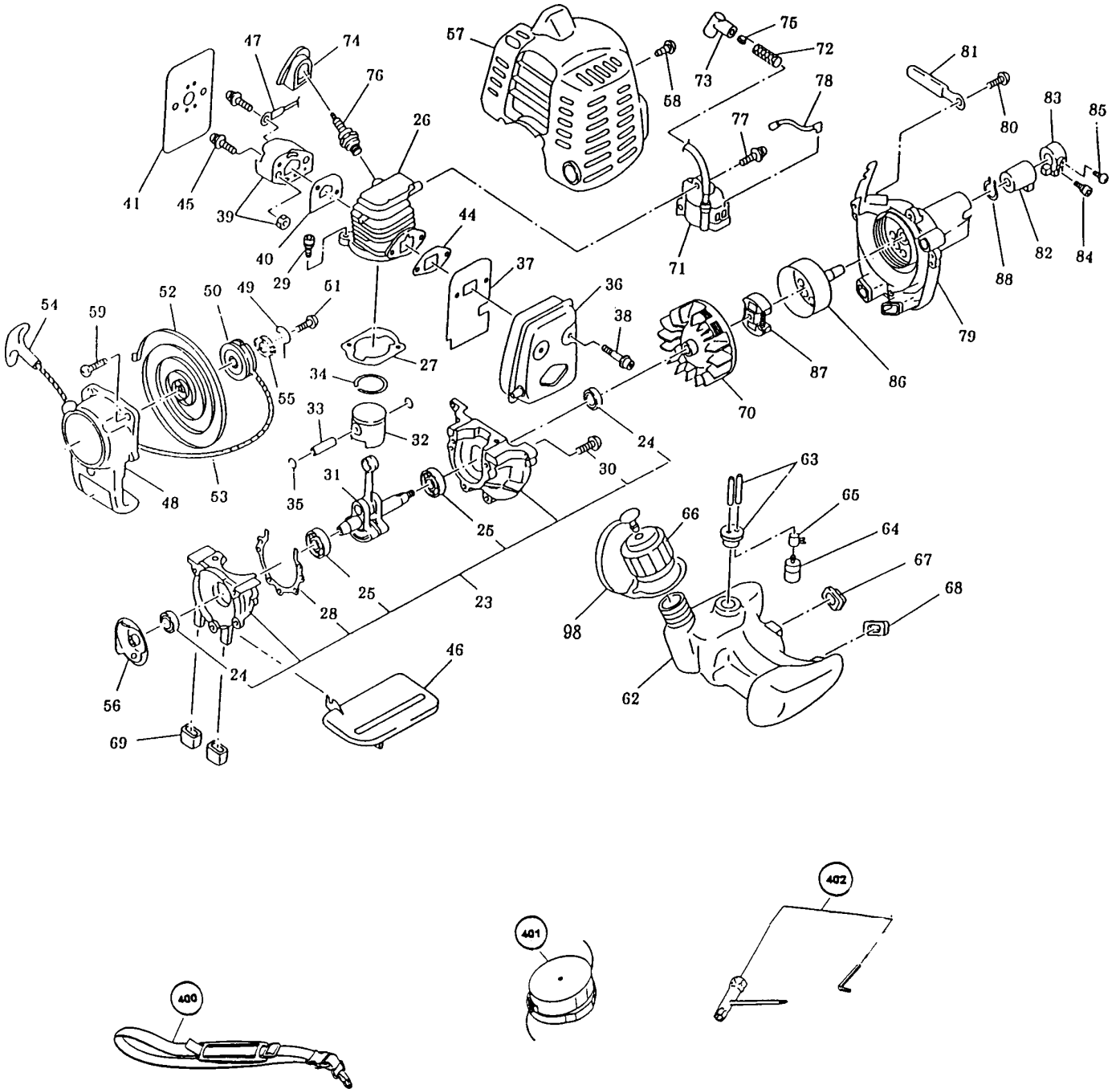

MS-20 C

DOLMAR



Page	Pos.	MS-20 C	MS-22 C	Part No.	Notes	Description	Specifications
2	23	1		383 100 400		CRANK CASE ASS'Y	INC. 24,25,28,30
2	24	2		374 010 998		OIL SEAL	
2	25	2		381 010 998		BALL BEARING	6000
2	26	1		374 150 070		CYLINDER	
2	27	1		382 150 030		CYLINDER GASKET	
2	28	1		318 150 040		CRANKCASE GASKET	
2	29	2		382 905 973		SOCKET HEAD BOLT	M5X20
2	30	3		388 005 950		SCREW	M5X25
2	31	1		374 200 100		CRANKSHAFT COMPLETE	
2	32	1		381 250 080		PISTON	
2	33	1		367 250 050		PISTON PIN	
2	34	1		367 250 060		PISTON RING	
2	35	2		388 508 997		CLIP	
2	36	1		368 300 100		EXHAUST MUFFLER	
2	37	1		381 350 000		MUFFLER INSULATOR	
2	38	2		367 905 952		SOCKET HEAD BOLT	M5X40
2	39	1		381 301 400		INSULATOR COMPL.	
2	40	1		377 350 050		INSULATOR GASKET	
2	41	1		374 350 040		CARBURETOR GASKET	
2	44	1		377 350 020		GASKET (MUFFLER)	
2	45	2		388 005 950		SCREW	M5X25
2	46	1		383 350 010		PLATE	
2	47	1		381 550 020		WIRE	
2	48	1		381 500 900	Y-04518	REWIND STARTER ASS'Y	INC. 49-56
2	49	1		367 500 210		SWING ARM	
2	50	1		383 500 203		REEL	
2	51	1		367 500 206		SET SCREW	
2	52	1		381 500 205		SPIRAL SPRING	
2	53	1		388 501 602		STARTER ROPE	
2	54	1		388 500 402		HANDLE	
2	55	1		367 500 211		COLLAR	
2	56	1		367 550 000		PULLEY	
2	57	1		377 550 120		CYLINDER COVER	
2	58	1		377 150 050		TAPPING SCREW	
2	59	3		367 360 425		SCREW ASS'Y	M4X25
2	62	1		381 650 000		FUEL TANK	
2	63	1		374 113 995		TUBE	
2	64	1		382 650 390		FILTER	
2	65	1		382 650 170		HOSE CLAMP	
2	66	1		377 601 400		FUEL TANK CAP	
2	67	1		381 650 020		PLATE	
2	68	1		381 650 030		PLATE	
2	69	2		381 650 025		DAMPER	
2	70	1		381 700 101		FLYWHEEL	
2	71	1		381 700 102		IGNITION COIL	
2	72	1		374 111 993		TUBE	
2	73	1		374 500 994		PLUG CAP	
2	74	1		388 750 010		PLUG CAP COVER	
2	75	1		377 400 993		PLUG CAP SPRING	
2	76	1		374 014 981		SPARK PLUG	
2	77	1		367 004 992		SCREW ASS'Y	M4X20
2	78	1		367 701 800		WIRE COMPLETE	
2	79	1		374 500 400		CLUTCH CASE COMPLETE	
2	80	3		381 005 998		TAPPING SCREW	M5X20
2	81	1		374 605 998		CLAMP	
2	82	1		374 150 020		PIPE DAMPER	
2	83	1		374 100 200		PIPE BRACKET	
2	84	1		383 905 988		SOCKET HEAD BOLT	M5X25
2	85	1		377 150 050		TAPPING SCREW	
2	86	1		383 200 100		CLUTCH DRUM COMPLETE	
2	87	1		381 200 200		CLUTCH	
2	88	1		374 151 000		OUTER SNAP RING	10
2	98	1		377 502 100		STRAP UNIT	
2	400	1		367 700 300		BAND ASS'Y	
2	401	1	1	381 224 267		NYLON CUTTING HEAD (BUMP& FEED)	BF4L
2	402	1		381 900 600		TOOL KIT	

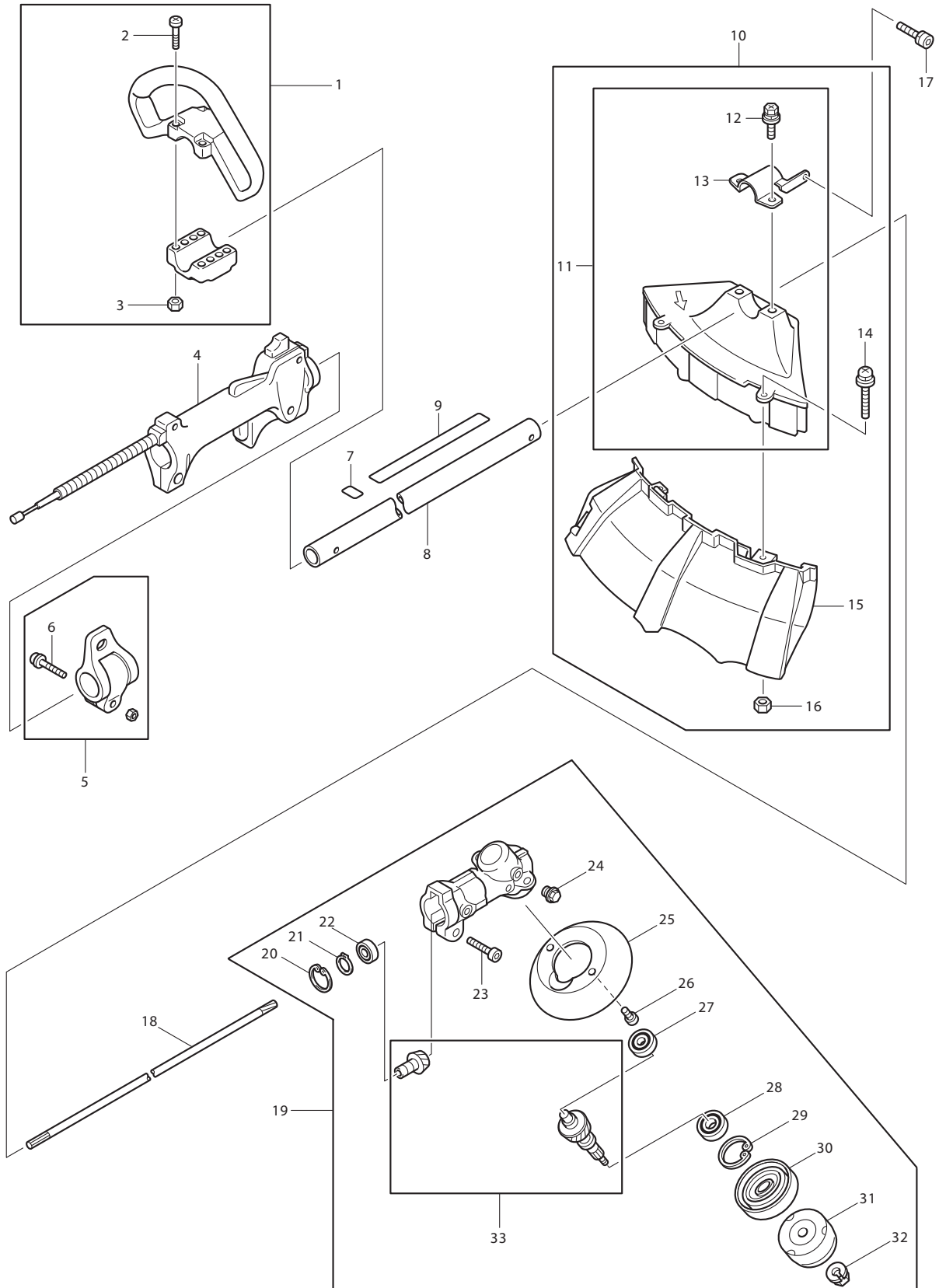

MS-22 C

DOLMAR



Page	Pos.	MS-20 C	MS-22 C	Part No.	Notes	Description	Specifications
3	1		1	374 401 700		HANDLE SET	INC. 2,3
3	2		4	374 401 603		SCREW	
3	3		4	381 270 500		NUT	M5
3	4		1	374 502 100		CONTROL LEVER ASS'Y	INC. 152-160, SECTION 6
3	5		1	381 700 500		HANGER ASS'Y	INC. 6
3	6		1	381 005 936		SCREW & WASHER ASS'Y	
3	7		1	367 951 470		CAUTION LABEL	
3	8		1	374 100 100		SHAFT PIPE COMPLETE	
3	9		1	374 952 130		CAUTION LABEL	
3	10		1	374 801 400	STANDARD EQUIPMENT	PROTECTOR ASSY	INC. 11,14-16
3	11		1	367 806 100	STANDARD EQUIPMENT	PROTECTOR ASS'Y	INC. 12,13
3	12		2	381 006 979		BOLT	M6X30
3	13		1	382 850 820		PROTECTOR CLAMP	
3	14		2	381 005 938		SCREW ASSEMBLY	
3	15		1	367 800 800		PROTECTOR COMPLETE	
3	16		2	367 180 500		NUT	M5
3	17		1	367 905 949		SOCKET HEAD BOLT	M5X14 (W,SW)
3	18		1	367 150 630		SHAFT	
3	19		1	382 300 600		CASE,GEAR ASSY	INC. 20-33
3	20		1	381 142 400		INNER SNAP RING	
3	21		1	374 300 612		OUTER SNAP RING	
3	22		1	381 250 030		BALL BEARING	#609ZZ
3	23		1	367 905 989		SOCKET HEAD BOLT	M5X25
3	24		1	367 301 101		OIL BOLT	M6X9
3	25		1	381 850 020		GUARD	
3	26		2	381 005 939		SCREW ASSEMBLY	
3	27		1	367 006 999		BALL BEARING	626ZZ
3	28		1	388 010 991		BALL BEARING	6000DDU
3	29		1	381 142 600		INNER SNAP RING	
3	30		1	367 850 160		RECEIVE WASHER	
3	31		1	381 800 300		CLAMP COMPL. WASHER	
3	32		1	367 850 500		NUT	
3	33		1	388 300 800		CUTTER SHAFT SET	

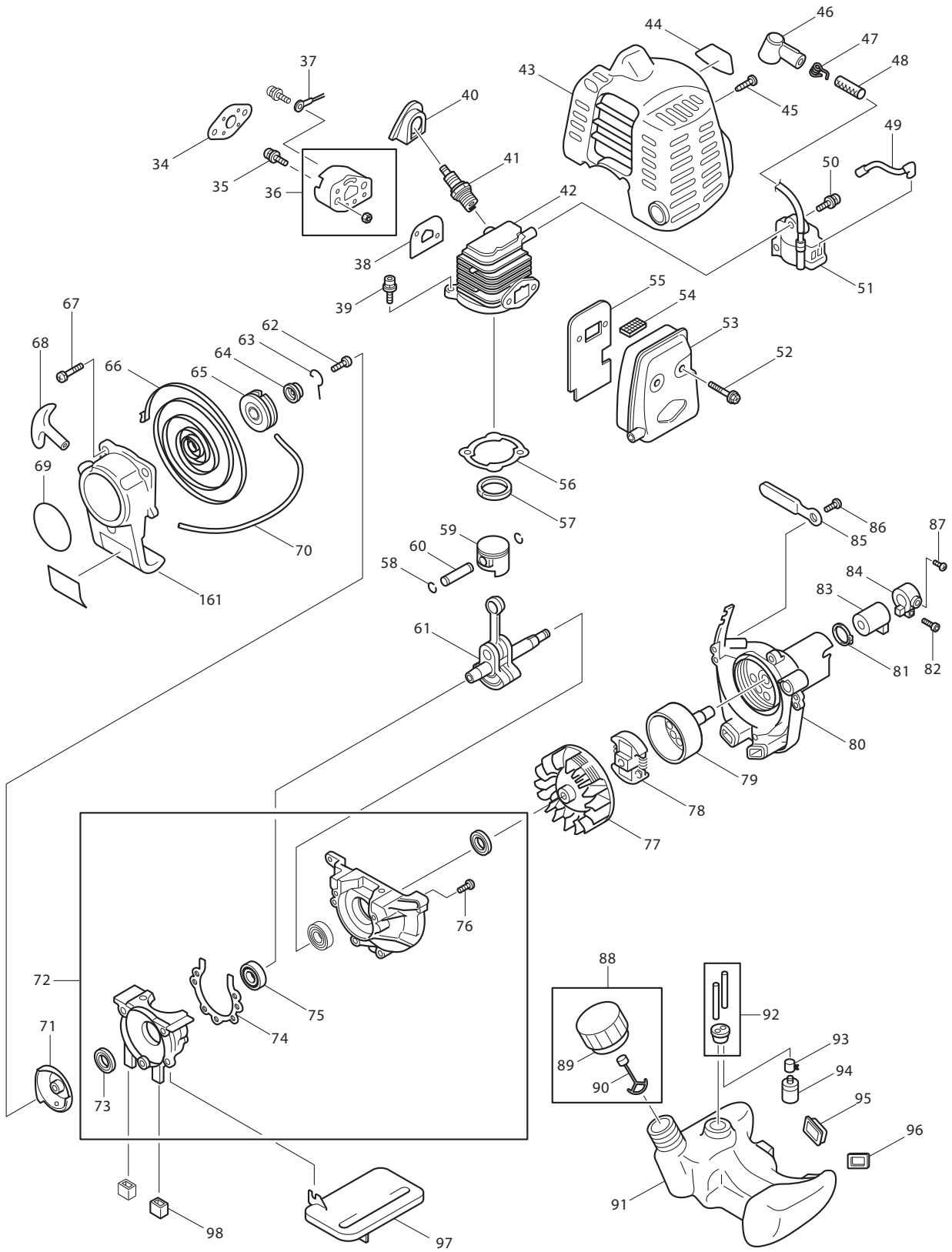

MS-22 C

DOLMAR



Page	Pos.	MS-20 C	MS-22 C	Part No.	Notes	Description	Specifications
4	34		1	381 350 280		SPACER GASKET	
4	35		2	388 005 950		SCREW	M5X25
4	36		1	381 301 400		INSULATOR COMPL.	
4	37		1	381 550 020		WIRE	
4	38		1	377 350 050		INSULATOR GASKET	
4	39		2	382 905 973		SOCKET HEAD BOLT	M5X20
4	40		1	388 750 010		PLUG CAP COVER	
4	41		1	374 014 971		SPARK PLUG	
4	42		1	381 150 090		CYLINDER	
4	43		1	374 550 300		COVER,CYLINDER	HD
4	44		1	381 950 810		TRADE MARK LABEL "DOLMAR"	
4	45		1	388 005 979		TAPPING SCREW	5X14
4	46		1	388 500 987		PLUG CAP	
4	47		1	377 400 993		PLUG CAP SPRING	
4	48		1	374 108 995		TUBE	
4	49		1	374 701 800		WIRE COMPL.	
4	50		2	381 004 977		SCREW ASSY	M4X16(W,SW)
4	51		1	374 701 101		IGNITION COIL	
4	52		1	367 905 952		SOCKET HEAD BOLT	M5X40
4	53		1	368 300 100		EXHAUST MUFFLER	
4	54		1	374 300 105		SPARK ARRESTER	
4	55		1	383 350 000		INSULATOR,MUFFLER	
4	56		1	382 150 030		CYLINDER GASKET	
4	57		1	374 250 050		PISTON RING	
4	58		2	388 508 997		CLIP	
4	59		1	374 250 170		PISTON	
4	60		1	367 250 050		PISTON PIN	
4	61		1	388 200 100		CRANKSHAFT COMPLETE	
4	62		1	367 500 206		SET SCREW	
4	63		1	367 500 210		SWING ARM	
4	64		1	367 500 211		COLLAR	
4	65		1	383 500 203		REEL	
4	66		1	381 500 205		SPIRAL SPRING	
4	67		3	381 004 977		SCREW ASSY	M4X16(W,SW)
4	68		1	388 500 402		HANDLE	
4	69		1	374 952 050		MODEL LABEL	
4	70		1	388 501 602		STARTER ROPE	
4	71		1	367 550 000		PULLEY	
4	72		1	383 100 400		CRANK CASE ASS'Y	INC. 73-76
4	73		2	374 010 998		OIL SEAL	
4	74		1	318 150 040		CRANKCASE GASKET	
4	75		2	381 010 998		BALL BEARING	6000
4	76		3	388 005 952		SCREW	M5X25
4	77		1	374 701 701		FLYWHEEL	
4	78		1	381 200 200		CLUTCH	
4	79		1	383 200 100		CLUTCH DRUM COMPLETE	
4	80		1	374 500 400		CLUTCH CASE COMPLETE	
4	81		1	374 151 000		OUTER SNAP RING	
4	82		1	383 905 988		SOCKET HEAD BOLT	M5X25
4	83		1	374 150 020		PIPE DAMPER	
4	84		1	374 150 130		PIPE BRACKET	
4	85		1	374 605 998		CLAMP	
4	86		3	374 005 978		TAPPING SCREW	M5X20
4	87		1	374 905 985		SOCKET HEAD BOLT	M5X14
4	88		1	377 605 900		FUEL TANK CAP COMPLETE	INC. 89,90
4	89		1	374 605 800		FUEL TANK CAP	
4	90		1	374 606 700		STRAP	
4	91		1	382 650 000		FUEL TANK	
4	92		1	374 115 992		TUBE	
4	93		1	381 105 999		HOSE CLAMP	
4	94		1	382 650 390		FILTER	
4	95		1	381 650 020		PLATE	
4	96		1	381 650 030		PLATE	
4	97		1	383 350 010		PLATE	
4	98		2	381 650 025		DAMPER	

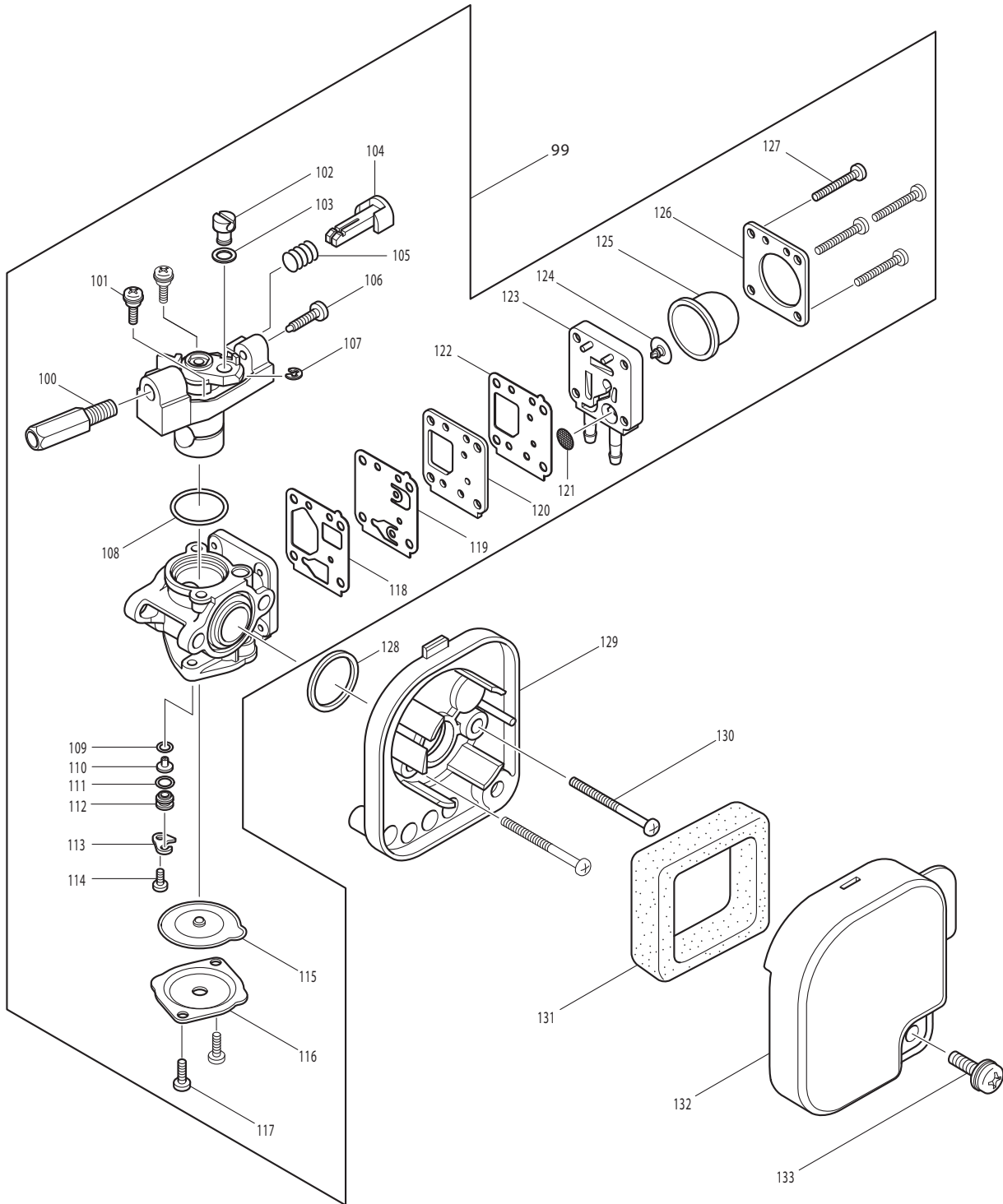

MS-22 C

DOLMAR



Page	Pos.	MS-20 C	MS-22 C	Part No.	Notes	Description	Specifications
5	99		1	374 603 600		CARBURETOR	INC. 100-127
5	100		1	374 601 924		ADJUST SCREW	
5	101		2	374 601 931		SCREW	
5	102		1	374 601 945		LEVER END	
5	103		1	374 601 946		WASHER	
5	104		1	374 603 601		STARTER LEVER	
5	105		1	374 603 602		STARTER SPRING	
5	106		1	374 601 925		SLOW STOP SCREW	
5	107		1	374 601 951		E-RING	
5	108		1	374 601 922		O-RING	
5	109		1	374 601 915		O-RING	
5	110		1	381 603 201		MAIN JET	
5	111		1	374 601 941		O-RING	
5	112		1	374 601 936		CHECK VALVE ASSY	
5	113		1	374 601 942		GUIDE PLATE	
5	114		1	374 601 943		SCREW	
5	115		1	374 601 904		DIAPHRAGM ASSY	
5	116		1	374 601 905		DIAPHRAGM COVER	
5	117		2	374 601 906		SCREW	
5	118		1	374 601 911		PUMP PACKING	
5	119		1	374 601 912		PUMP DIAPHRAGM	
5	120		1	374 601 935		PUMP PLATE	
5	121		1	374 601 933		FILTER	
5	122		1	374 601 913		PUMP PACKING	
5	123		1	374 601 934		PUMP COVER	
5	124		1	374 600 903		COMBINATION VALVE	
5	125		1	374 600 904		PRIMING PUMP	
5	126		1	374 601 932		PRIMING PUMP PLATE	
5	127		4	374 601 914		SCREW	
5	128		1	374 301 704		O-RING	
5	129		1	374 301 801		PLATE,AIR CLEANER ASSY	
5	130		2	381 310 560		PAN HEAD SCREW	M5X60
5	131		1	374 301 703		ELEMENT,AIR	CLEANER
5	132		1	374 301 802		CASE,AIR CLEANER	
5	133		1	381 005 948		SCREW ASS'Y	M5X14

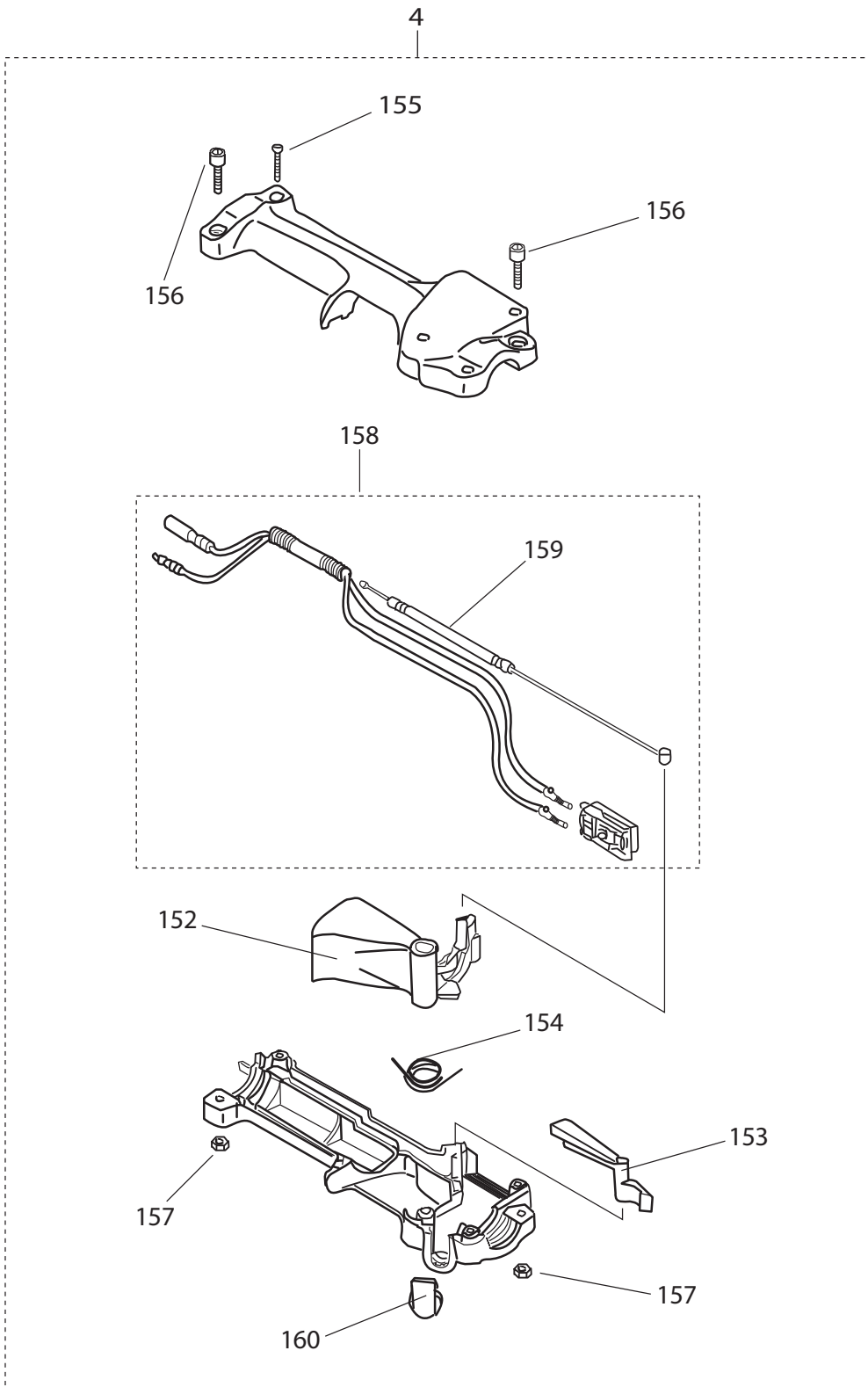

MS-22 C

DOLMAR



Page	Pos.	MS-20 C	MS-22 C	Part No.	Notes	Description	Specifications
6	4		1	374 502 100		CONTROL LEVER ASS'Y	INC. 152-160
6	152		1	374 500 603		LEVER	
6	153		1	367 502 306		LEVER	
6	154		1	367 500 605		SPRING	
6	155		4	367 500 606		TAPPING SCREW	M4X20
6	156		2	374 905 972		SOCKET HEAD BOLT	M5X20
6	157		2	374 501 116		NUT	
6	158		1	374 502 101		WIRE SET	INC. 159
6	159		1	374 502 102		CONTROL CABLE	
6	160		1	381 500 615		TOP	
6	*A01		1	381 900 600	STANDARD EQUIPMENT	TOOL KIT	INC. A04
6	*A01		1	374 700 300	STANDARD EQUIPMENT	BAND ASS'Y	
4	401	1	1	381 224 267	STANDARD EQUIPMENT	NYLON CUTTING HEAD (BUMP& FEED)	BF4L
6	*A04		1	374 704 999	STANDARD EQUIPMENT	HEX. WRENCH	
4	161		1	381 500 900	Y-04518	STARTER ASSY.. CPL. INCLUDES 62-66	
	* NO PICT.						

MS-20 C	1	Pipe, handle, protector, carburetor, air cleaner
	2	Engine, starter, clutch, fuel tank, accessories
MS-22 C	3	Pipe, handle, protector, bevel gear
	4	Engine, starter, clutch, fuel tank
	5	Carburetor, air cleaner
	6	Control lever, accessories

	Key to symbols
⇒ 1999999 2000000 ⇒ 2003.04 ⇒ TI 2003/07 Acc. = { m Corr.	Production to serial number New part from serial number New part from Year / Month See Technical Information Year / No. Accessories (not included in the delivery inventory) No standard execution, may be used Contains item number Sold by the meter Error correction
	Specifications subject to change without notice